

Analogue remote control units FBR 1, FBR 2

Technical Information · GB

10 Edition 07.10

CE

- It is distinguished by a timeless design which integrates seamlessly with your living space
- Easy to fit due to removable control unit
- Easy setting of operating mode and room temperature allows immediate use after installation
- Integrated room temperature sensor



krom //
schroder

Table of contents

Analogue remote control units FBR 1, FBR 2	1
Table of contents	2
1 Application	3
2 Certification	4
3 Functioning	5
3.1 Electrical connection diagrams	6
4 Project planning information	7
4.1 Electrical connection	7
4.2 Installation	7
5 Technical data	8
5.1 Dimensions	8
Feedback	9
Contact	9

1 Application

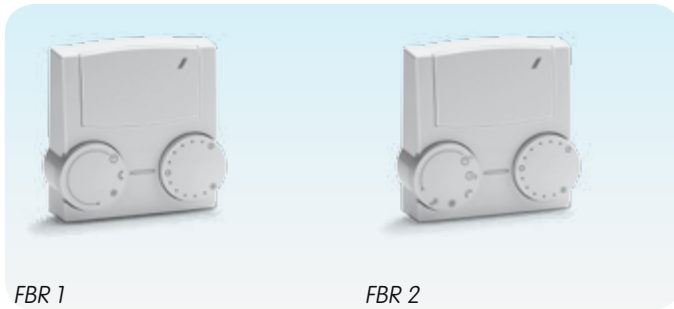

FBR 1

FBR 2

The FBR 1 and FBR 2 integrate well with the living space due to their timeless design.

FBR 1 and FBR 2 are analogue remote control units with an integrated room temperature sensor. The FBR 1 is directly connected to the FBR input on the K1, E8 or E25 heating controller. The FBR 2 is directly connected to the FBR input on the E8, Merlin or Lago heating controller, see page 6 (Electrical connection diagrams).

With the FBR 1 and FBR 2 remote controls it becomes possible to move various operating functions, such as night mode with setback temperature, day mode with comfort temperature or automatic mode according to time, as well as setting the desired room temperature, from the heating controller into the living space itself.

2 Certification



EMC conditions in accordance with EN 60730-1 and EN 60730-2-9.

The devices are in compliance with the EMC Directive and the Low Voltage Directive.

3 Functioning

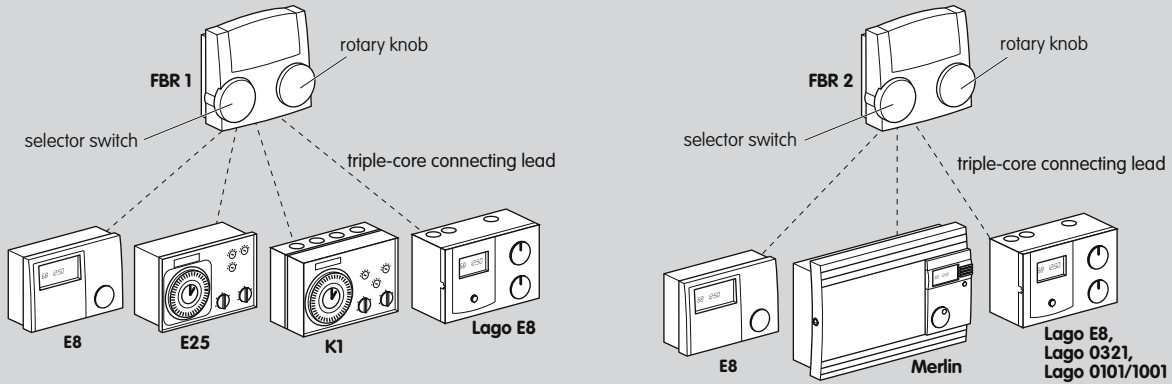

The selector switch on the FBR can be used to select the following operating modes on a heating controller for one heating circuit respectively:

- night mode with setback temperature,
- day mode with comfort temperature,
- automatic mode according to time program.

When the FBR 2 is in automatic mode it also provides the option to select two time programs and summer mode with hot water preparation while the heating circuit is switched off.

The room sensor integrated in the FBR measures the room temperature. The rotary knob can be used to adjust the desired room temperature within a ± 5 °C range. The corresponding selector switch or rotary knob positions, as well as the measured room temperature, are transmitted to the heating controller via a triple-core connecting lead.

3.1 Electrical connection diagrams

FBR 1 with K1

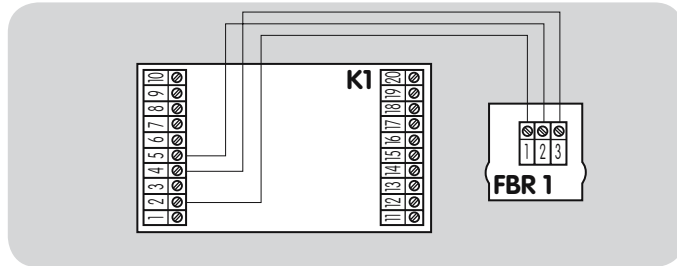

FBR 1 with E25

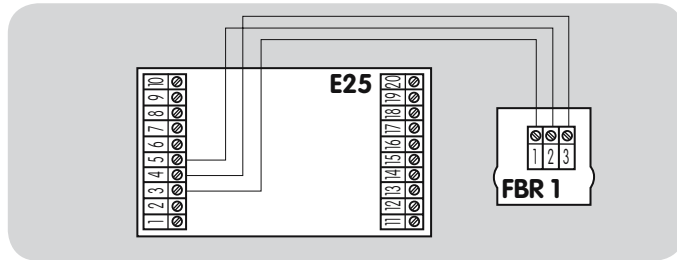

FBR 1 and/or FBR 2 with E8 and Lago E8

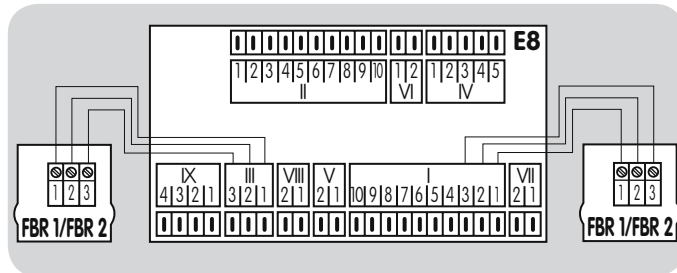

FBR 2 with Merlin

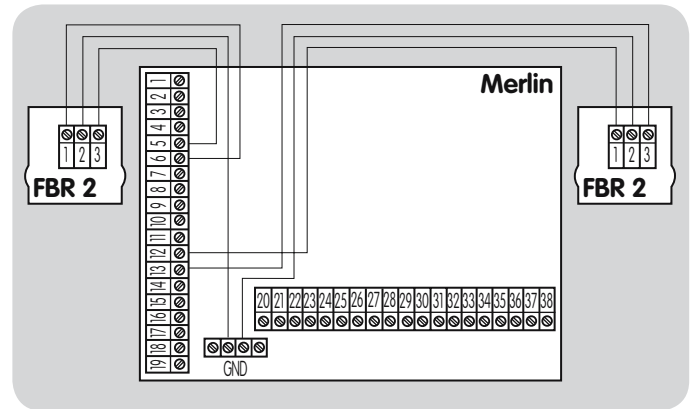

FBR 2 with Lago 0321 and Lago 0101/1001

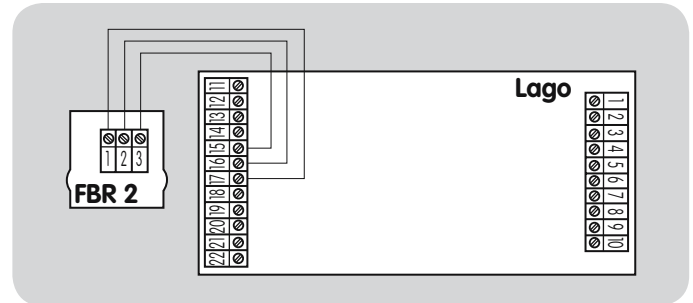

4 Project planning information

4.1 Electrical connection

Terminal for triple-core connecting lead on FBR base, see page 6 (Electrical connection diagrams).

FBR 2

A three-pole Rast 5 plug with screw terminals for connection to an E8 heating controller or Lago E8 is included with the FBR 2.

Connecting lead

The ohmic resistance of the connecting lead affects the desired value adjustment and the room temperature measurement.

Example FBR 1: A connecting lead with $\varnothing 0.25 \text{ mm}^2$ (telephone line) and a length of 10 m causes the desired room temperature to increase by $0.2 \text{ }^\circ\text{C}$ and the room temperature measurement to increase by $0.5 \text{ }^\circ\text{C}$.

Example FBR 2: A connecting lead with $\varnothing 0.25 \text{ mm}^2$ (telephone line) and a length of 10 m causes the desired room temperature to increase by $0.02 \text{ }^\circ\text{C}$ and the room temperature measurement to decrease by $0.01 \text{ }^\circ\text{C}$.

4.2 Installation

The remote control unit should be fitted in the reference / main living room of the respective heating circuit for best heating performance.

With activated room sensor influence on the heating controller, the radiators and any other devices that give off heat should be as far removed from the FBR as possible. The FBR should be fitted to an interior wall in an area not affected by draught or direct sunlight.

5 Technical data

Protection class: IP40 according to EN 60529.

Protection class: III according to EN 60730.

Ambient temperature:

During operation: 0 to 50°C,

in storage: -20 to 60 °C.

Permissible relative humidity: 95% RH, not condensing.

Room sensor:

FBR 1: 1 kΩ PTC measurement resistor,

FBR 2: 5 kΩ NTC measurement resistor.

5.1 Dimensions

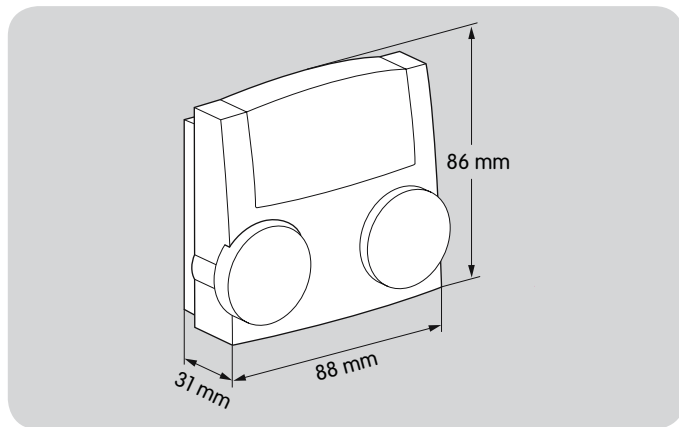

Base

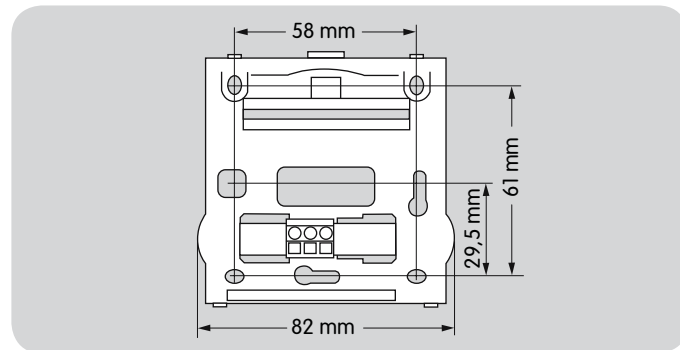

Feedback

Finally, we are offering you the opportunity to assess this “Technical Information (TI)” and to give us your opinion, so that we can improve our documents further and suit them to your needs.

Clarity

Found information quickly
Searched for a long time
Didn't find information
What is missing?
No answer

Comprehension

Coherent
Too complicated
No answer

Scope

Too little
Sufficient
Too wide
No answer



Use

To get to know the product
To choose a product
Planning
To look for information

Navigation

I can find my way around
I got “lost”
No answer

My scope of functions

Technical department
Sales
No answer

Remarks

(Adobe Reader 7 or higher required)
www.adobe.com



Contact

Elster GmbH
Postfach 2809 · 49018 Osnabrück
Strothweg 1 · 49504 Lotte (Büren)
Germany
T +49 541 1214-0
F +49 541 1214-370
info@kromschroeder.com
www.kromschroeder.com

The current addresses of our international agents are available on the Internet:
www.kromschroeder.de/index.php?id=718&L=1

We reserve the right to make technical modifications in the interests of progress.
Copyright © 2014 Elster GmbH
All rights reserved.